



## Universal Multi-Bag Filter Vessel 远诺旋转开盖多袋过滤器

### MFSA Series MFSA 系列

**Nothing is too large the flow we can't handle  
for your filtration need!**

满足高达 1,000 m<sup>3</sup>/hour 的大流量需求

远诺多袋过滤器适用于大流量过滤, 从 3 袋至 24 袋, 规格齐全, 最大流量高达 1000 立方米/小时, 所有滤器均参照 ASME 标准设计。

Our user friendly design multi bag filter with construction from 3 bags to 24 bags to meet larger liquid flow rate requirement up to 1,000 m<sup>3</sup>/hr, all bag filter design in ASME VIII see VIII DIV I standard.

### Features 特点

- 独特的机械弹簧旋转开盖
- 易操作、高经济性的袋式过滤器
- 每个滤袋有单独的锁紧装置确保滤器和滤袋间良好的密封作用
- 3 点平衡紧锁滤袋, 确保无侧漏
- 参照 ASME 标准设计
- 规格有 3 至 24 袋可供选择
- 适用大流量和大固含量场合



滤器型号 Vessel Type	滤袋尺寸 Size	滤袋数量 No. of Filter Bag	理论流量 (取决于介质) Theoretical Flow Rate	最大操作压力 Max. Operating Pressure	最高操作温度 Max. Operating Temperature	过滤面积 Filter Area	进出口法兰 Inlet/Outlet
MF2A2-10-030A-SA	#02	2	80 m <sup>3</sup> /hour	10.0bar	120°C	1.0 m <sup>2</sup>	3" - 4"
MF3A2-10-030A-SA	#02	3	120 m <sup>3</sup> /hour	10.0bar	120°C	1.5 m <sup>2</sup>	3" - 4"
MF4A2-10-040A-SA	#02	4	160 m <sup>3</sup> /hour	10.0bar	120°C	2.0 m <sup>2</sup>	3" - 6"
MF5A2-10-040A-SA	#02	5	200 m <sup>3</sup> /hour	10.0bar	120°C	2.5 m <sup>2</sup>	4" - 6"
MF6A2-10-060A-SA	#02	6	240 m <sup>3</sup> /hour	10.0bar	120°C	3.0 m <sup>2</sup>	4" - 6"
MF8A2-10-060A-SA	#02	8	320 m <sup>3</sup> /hour	10.0bar	120°C	4.0 m <sup>2</sup>	6" - 8"
MF10A2-10-080A-SA	#02	10	400 m <sup>3</sup> /hour	10.0bar	120°C	5.0 m <sup>2</sup>	8" - 10"
MF12A2-10-080A-SA	#02	12	480 m <sup>3</sup> /hour	10.0bar	120°C	6.0 m <sup>2</sup>	8" - 10"
MF14A2-10-080A-SA	#02	14	560 m <sup>3</sup> /hour	10.0bar	120°C	7.0 m <sup>2</sup>	8" - 10"
MF16A2-10-100A-SA	#02	16	640 m <sup>3</sup> /hour	10.0bar	120°C	8.0 m <sup>2</sup>	8" - 12"
MF18A2-10-120A-SA	#02	18	720 m <sup>3</sup> /hour	10.0bar	120°C	9.0 m <sup>2</sup>	10" - 14"
MF20A2-10-140A-SA	#02	20	800 m <sup>3</sup> /hour	10.0bar	120°C	10.0 m <sup>2</sup>	10" - 16"
MF22A2-10-160A-SA	#02	22	880 m <sup>3</sup> /hour	10.0bar	120°C	11.0 m <sup>2</sup>	12" - 18"
MF24A2-10-180A-SA	#02	24	960 m <sup>3</sup> /hour	10.0bar	120°C	12.0 m <sup>2</sup>	14" - 18"

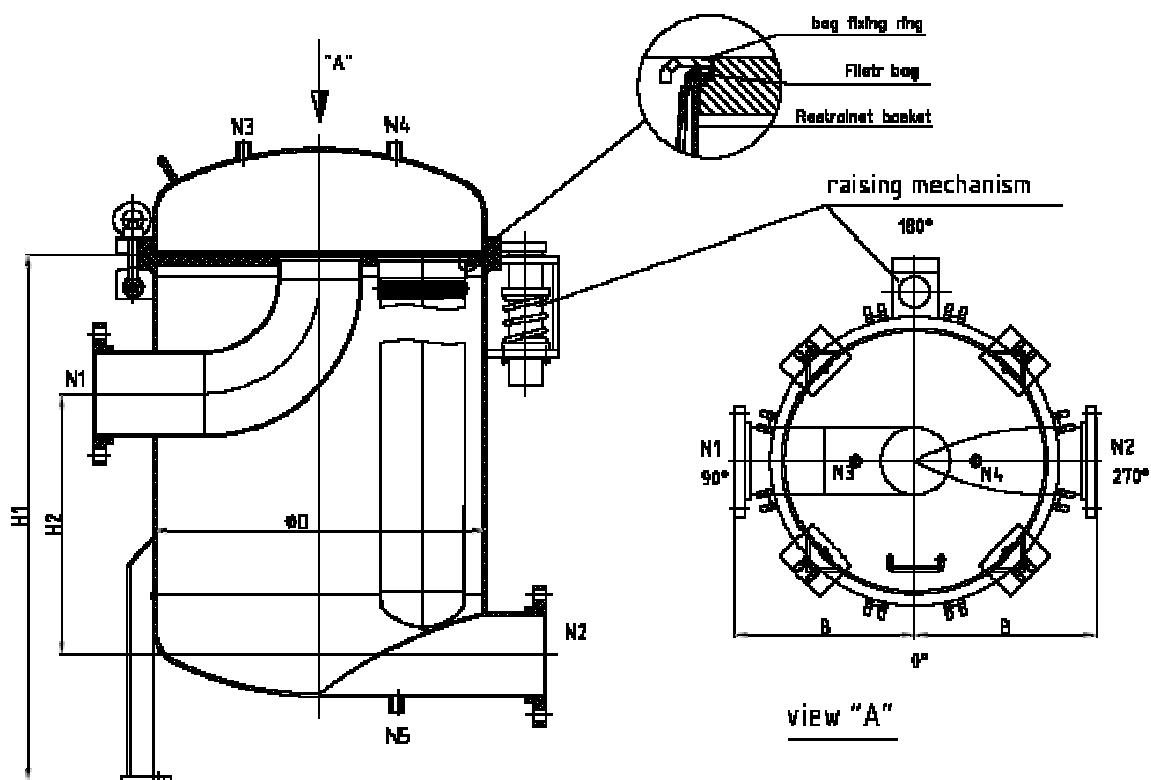

MF4	A2-	10-	040A-SA
单台滤器装配的 滤袋数量 No. of Bags per vessel  3, 4, 5, 6, 8, 10, 12, 14, 16, 18, 20, 22, 24	A - SS304 S - SS316 SL - SS316L  2 - #2	6 Bar 10 Bar 16 Bar 25 Bar	A - ANSI Flange 法兰 J - JIS Flange 法兰 D - DIN Flange 法兰  Flange Size 3", 4", 5", 6", 8", 10", 12", 14", 16", 18"

**选项**

- JIS 法兰、DIN 法兰、ANSI 法兰
- 加热外套适合高粘性液体
- 进出口方向可根据现场管线位置设计

- 材质: SS304、SS316L

**Options**

- JIS / DIN flange connection
- Heating jacket for high viscosity liquid
- Flexible inlet/ outlet orientation
- SS304/ SS316L material available

**配件**

- 内置浮球更换滤袋更加容易
- 磁棒吸附金属颗粒
- 精度滤篮可替换滤袋

**Accessories**

- Displacement balloon for easy bag changing
- Magnetic bar for metallic particle retention
- Mesh basket to convert to strainer

**应用领域**

电子、半导体、化工、制药、食品、饮料、油漆、造纸工业、汽车制造、油墨、树脂、水处理

**Applications**

- Chemical
- Pharmaceutical
- Food & Beverage
- Paint
- Automotive Coating
- Oil Refinery
- Marine
- Water Treatment

**Universal Multi-Bag Filter Vessel**  
 远诺旋转开盖多袋过滤器

**远诺过滤技术（上海）有限公司**  
**Universal Filtration (Shanghai) Co., Ltd.**

上海市浦东新区航头路 128 号 9 号楼  
 Building #9, No.128 Hangtou Road, Pudong  
 Shanghai 201316, P.R.China

Tel.: +86-21-2093 2026  
 Fax: +86-21-2093 2027  
 Email: sales-inquiry@universal-filtration.com.cn



更多信息请参阅我们的网站 [www.universal-filtration.com.cn](http://www.universal-filtration.com.cn)

设计、制造工业液体过滤系统：袋式过滤系统、芯式过滤系统、管道过滤器、自清洗过滤器、反清洗过滤系统等，销售网络遍布全球。